

PAMS Technical Documentation

NSD-1 Series Transceivers

UI Module UE4S

AMENDMENT RECORD SHEET

Amendment Number	Date	Inserted By	Comments
	08/99		Issue 1
Issue 2	09/00	OJuntune	ARS added v..6.3 parts list added p.15

CONTENTS

UIF Module UE4S	3
Introduction	3
The Engine Interface	3
Display	5
LCD Module Interface	5
Functional Description	7
Power Distribution Diagram	7
Display Circuit	7
Keyboard	8
Keyboard Matrix	9
Power Key	9
Backlighting	10
Display backlight	11
Keyboard backlight	11
Buzzer	11
Speaker	12
Parts list of UE4S (EDMS Issue 4.3) Code: 0201360	13
Parts list of UE4S (EDMS Issue 6.3) Code: 0201360	15
Schematic Diagrams of UE4S (at the back of the binder, A3 size)	
Block Diagram of UIF Module UE4S (v.3.0 Edit 49) for layout version 04	B-1
Circuit Diagram of Speaker (3.0 edit 29) and LCD (v.3.0 edit 29) v. 04	B-2
Circuit Diagram of Keyboard (Version3.0 Edit 45) for layout version 04	B-3
Circuit Diagram of Backlight (Version 3.0 Edit 27) for layout version 04	B-4
Layout Diagram of UE4S v.04	B-5

UIF Module UE4S

Introduction

The UI module UE4S is connected to the system/RF PCB with a 28-pin spring connector.

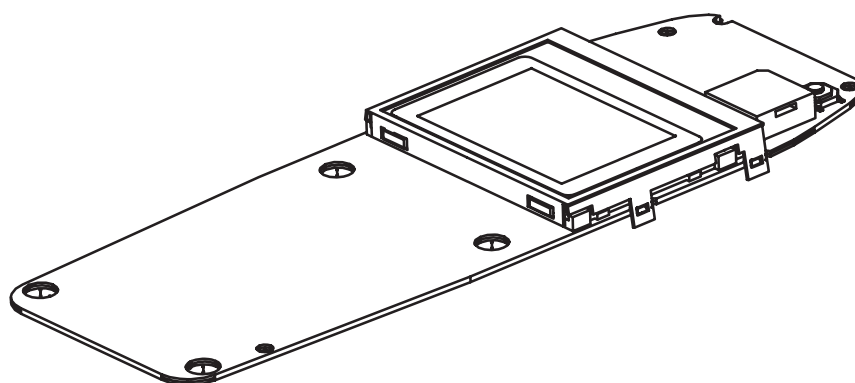

The Engine Interface

Pin	Line Symbol	Parameter	Min	Typ	Max	Unit	Notes
1	ROW0	Keyboard matrix row 0	0 0.7xVBB		0.3xVBB VBB	V	Low High
2	ROW1	Keyboard matrix row 1	0 0.7xVBB		0.3xVBB VBB	V	Low High
3	ROW2	Keyboard matrix row 2	0 0.7xVBB		0.3xVBB VBB	V	Low High
4	ROW3	Keyboard matrix row 3	0 0.7xVBB		0.3xVBB VBB	V	Low High
5	ROW4	Keyboard matrix row 4	0 0.7xVBB		0.3xVBB VBB	V	Low High
6	COL0	Keyboard matrix column 0, used for flip identification	0 0.7xVBB		0.3xVBB VBB	V	Flip Open Flip Closed
7	COL1	Keyboard matrix column 1	0 0.7xVBB		0.3xVBB VBB	V	Low High
8	COL2	Keyboard matrix column 2	0 0.7xVBB		0.3xVBB VBB	V	Low High

Pin	Line Symbol	Parameter	Min	Typ	Max	Unit	Notes
9	COL3	Keyboard matrix column 3	0 0.7xVBB		0.3xVBB VBB	V	Low High
10	COL4	Keyboard matrix column 4	0 0.7xVBB		0.3xVBB VBB	V	Low High
11	Signal1	Flip interrupt, not used	0 0.7xVBB		0.3xVBB VBB	V	
12	VF_IN	Flash in	4.8	5.0	5.2	V	Connected #13
13	VF_OUT	Flash out	4.8	5.0	5.2	V	Connected #12
14	VBATT	Battery voltage	3.0		5.1	V	
			60	75	100	mA	For lights
				110	300	mA	For buzzer
15	UAGND*	Analog ground		0		V	
16	PWRON	Power on key	0 0.7xVBB		0.3xVBB VBB	V	Low / Power on High
17	LCDCDX	LCD driver code/data selection	0 0.7xVBB		0.3xVBB VBB	V	Low High
18	SCLK	LCD driver serial clock	0 0.7xVBB		0.3xVBB VBB	V	Low High
			0		4.0	MHz	
19	SDA	LCD driver serial data	0 0.7xVBB		0.3xVBB VBB	V	Low High
20	LCDCSX	LCD driver chip select	0 0.7xVBB		0.3xVBB VBB	V	Low / Active High
21	LCDRSTX	LCD driver reset	0 0.7xVBB		0.3xVBB VBB	V	Low / Active High
22	UDGND*	Digital ground		0		V	
23	BUZZER	Buzzer PWM control	0		2.85	V	
24	VL	Supply voltage	2.7	2.8	2.85 300	V uA	
25	SPARE	Call indicator LED	0 0.7xVBB		0.3xVBB VBB	V	Not used in UI
26	LIGHT	Illumination control	0 0.7xVBB		0.3xVBB VBB	V	Low High / Active
27	EARN	Speaker neutral	0		1.78	V _{pp}	
28	EARP	Speaker positive	0		1.78	V _{pp}	

* Ground position is on connector NOT BATTERY.

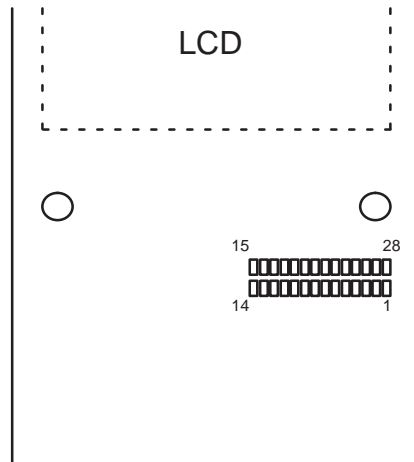

UIM connector pads viewed from the GND side

See the A3 diagrams for current schematics and component placement.

Display

Display LCD84x48 is full dot matrix display, with COG driver. Display size is 84 columns and 48 rows. With the display graphic images can be presented.

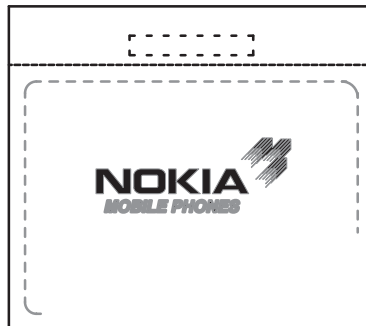

Figure 1. LCD cell DSL 84x48

LCD Module Interface

Pin	Line Symbol	Parameter	Minimum	Typical / Nominal	Maximum	Unit	Notes
1	VL	Supply voltage	2.7	2.8	2.85	V	
					300	uA	
2	SCLK	Serial clock input	0		4.0	MHz	VBB = 2.7V

Pin	Line Symbol	Parameter	Minimum	Typical / Nominal	Maximum	Unit	Notes
			0		VBB	V	
3	SDA	Serial data input	0 0.7xVBB		0.3xVBB VBB		
4	LCDCDX	Control/display data flag input	0 0.7xVBB		0.3xVBB VBB		Control Data
5	LCDCSX	Chip select input	0 0.7xVBB		0.3xVBB VBB		Active
6	OSC**	External clock for LCD	30.4	32.0	33.6	kHz	Connected to VBB on UI
7	UDGND*	Ground		0		V	
8	VOUT	DC/DC voltage converter output			9		
9	LCDRSTX	Reset	0 0.7xVBB		0.3xVBB VBB		Active

* Ground position is on connector NOT BATTERY.

** External oscillator is not used in UE4S.

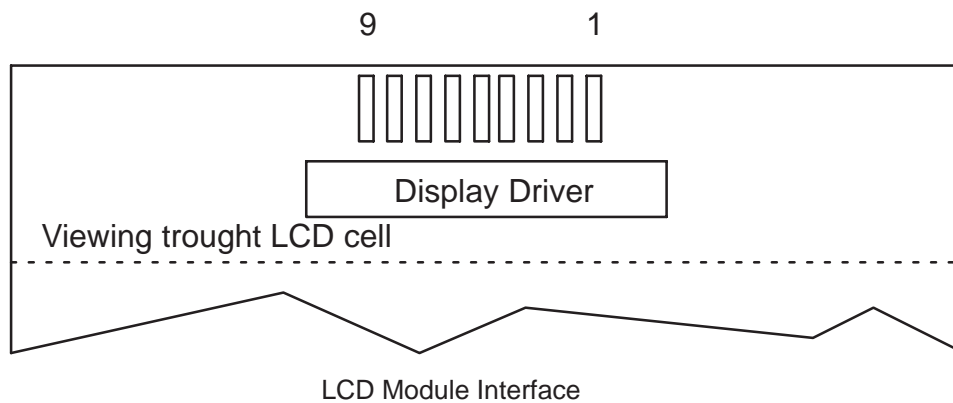

Functional Description

Power Distribution Diagram

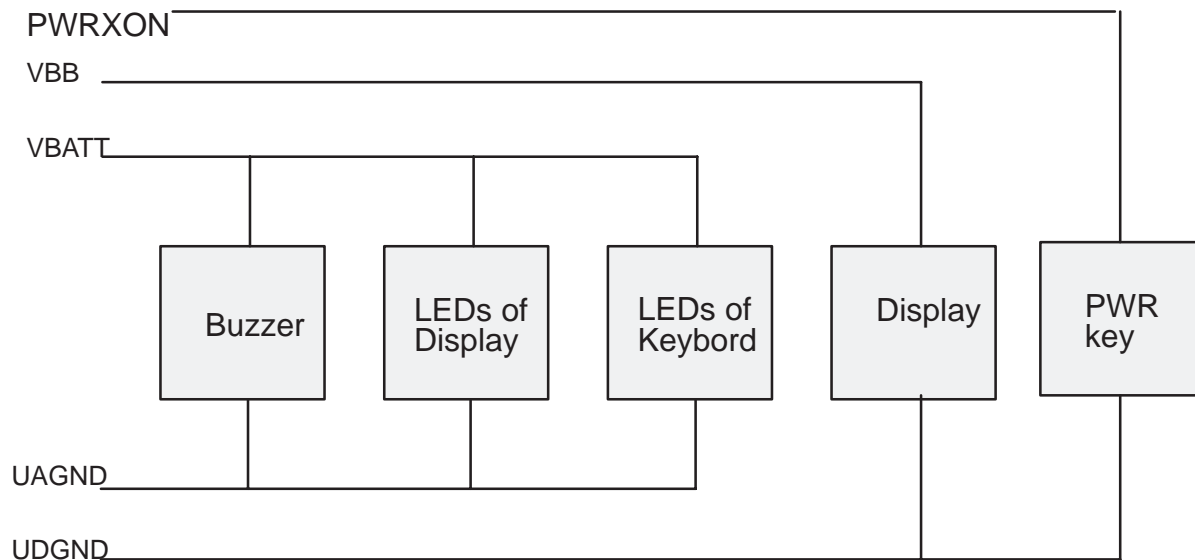

Display Circuit

The display circuit comprises a LCD module (GD40) and two capacitors. The LCD module employs the COG (Chip on Glass) technology. The LCD module is connected to the UI board with gold wired elastomer. The capacitors are placed on the UI PCB.

The display driver includes a hw-reset, voltage tripler or quadrupler which depends on temperature, temperature compensating circuit and a low power control. The driver includes 84x48 RAM memory which is used when elements are create on the LCD. The elements are created with software. The driver doesn't include CG-ROM. One bit in the RAM is same as one pixel on display.

Keyboard

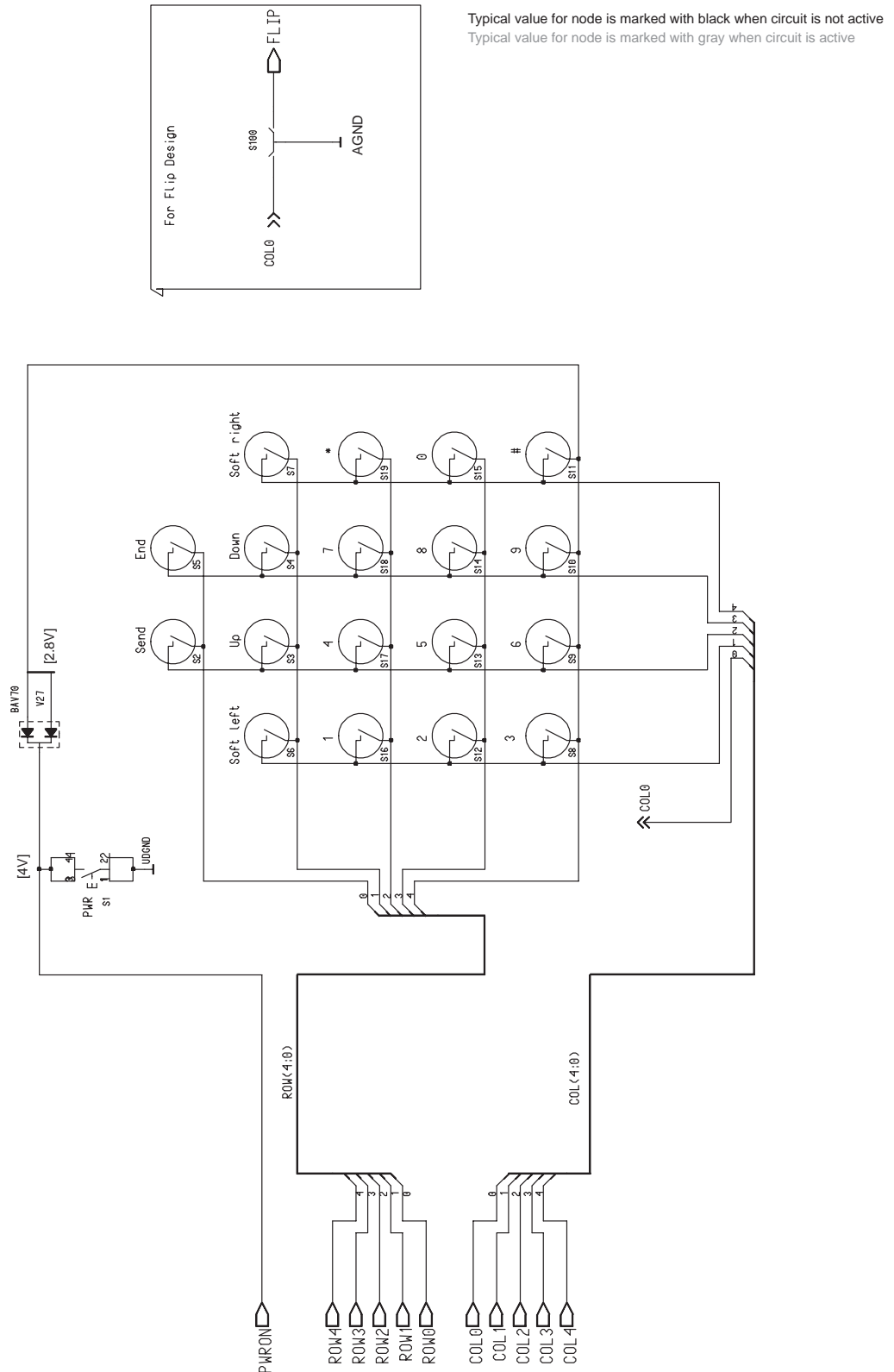

Keyboard Matrix

ROW/COL	0	1	2	3	4
0	FLIP	Side Key	Send	End/Mode	Side Key
1	NC	Soft left	Up	Down	Soft Right
2	NC	1	4	7	*
3	NC	2	5	8	0
4	PWR switch	3	6	9	#

NC = Not Connected

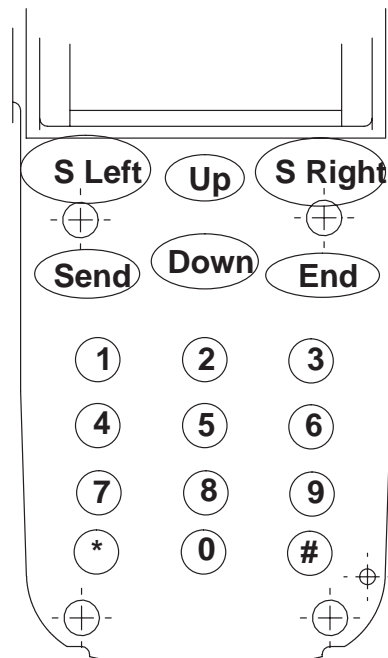

Power Key

A micro switch is used as a power key on UI module. Circuitry includes micro switch and two diodes which are needed for the MAD interface. The power key is connected to the CCONT. The power switch is active in LOW state. The power key circuit can be seen on the Display Circuit diagram. The power key is connected to ROW4.

Backlighting

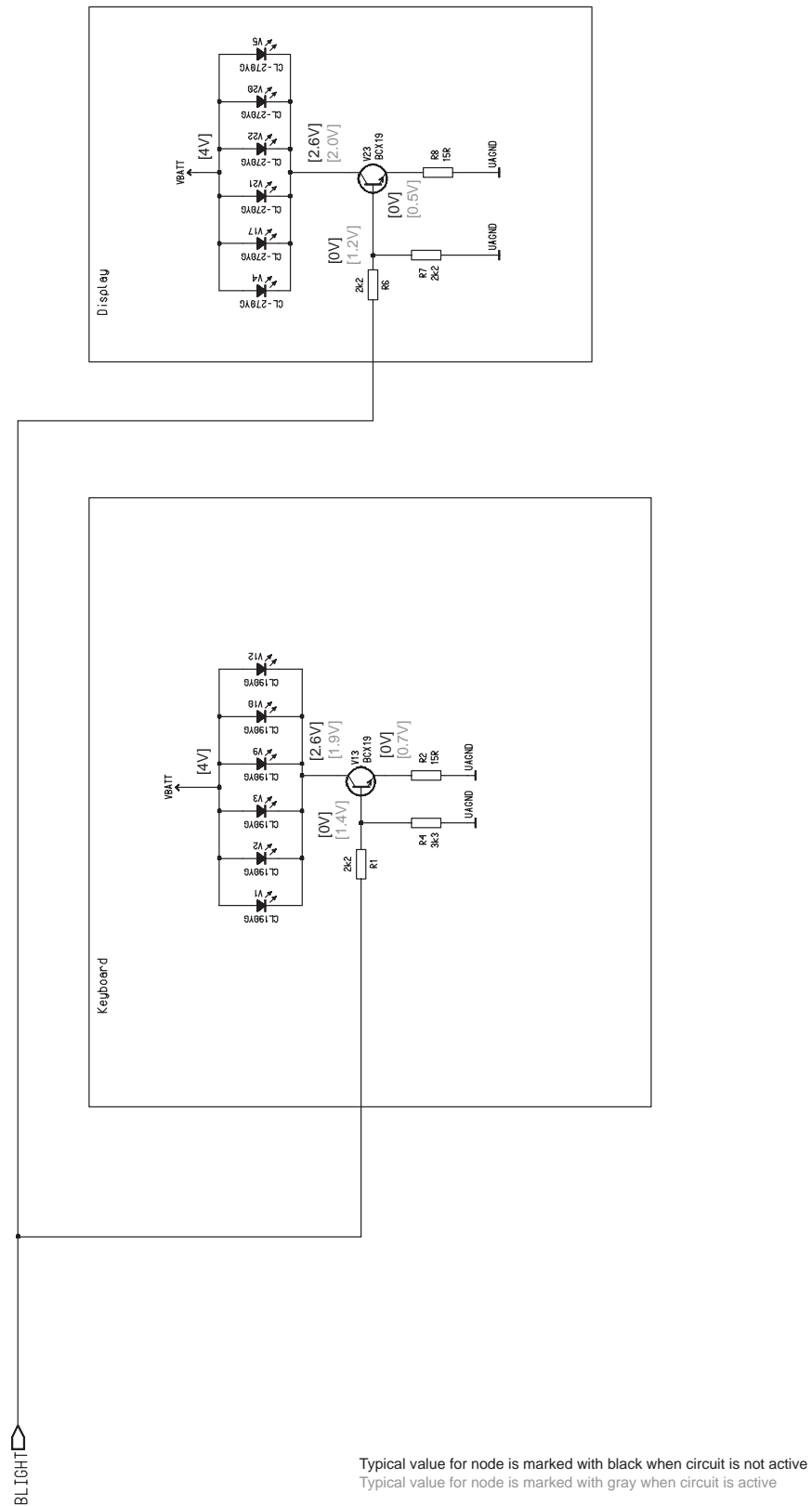

Display backlight

Backlighting is provided by LEDs, three LED on right and three on left side of the display. The LEDs are compatible with CL270-YG and are side illuminating. The light is on when LIGHT-signal is in HIGH state.

Pin	Line Symbol	Parameter	Minimum	Typical / Nominal	Maximum	Unit	Notes
14	VBAT	Battery voltage	3.0		5.1	V	Same supply for Buzzer & Keyboard
			43.4	51.4	59.6	mA	LEDs

Keyboard backlight

The keyboard backlighting comprises 6 LEDs. The LEDs are compatible with CL190-YG. Backlighting is on when LIGHT-signal is on HIGH state.

Color of LED is for

- Keyboard : yellow-green, $\lambda = 570\text{nm}$

Pin	Line Symbol	Parameter	Minimum	Typical / Nominal	Maximum	Unit	Notes
14	VBAT	Battery voltage	3.0		5.1	V	Same supply for Buzzer & Display
			55.3	62.4	69.9	mA	LEDs

Buzzer

Buzzer is of SMD type.

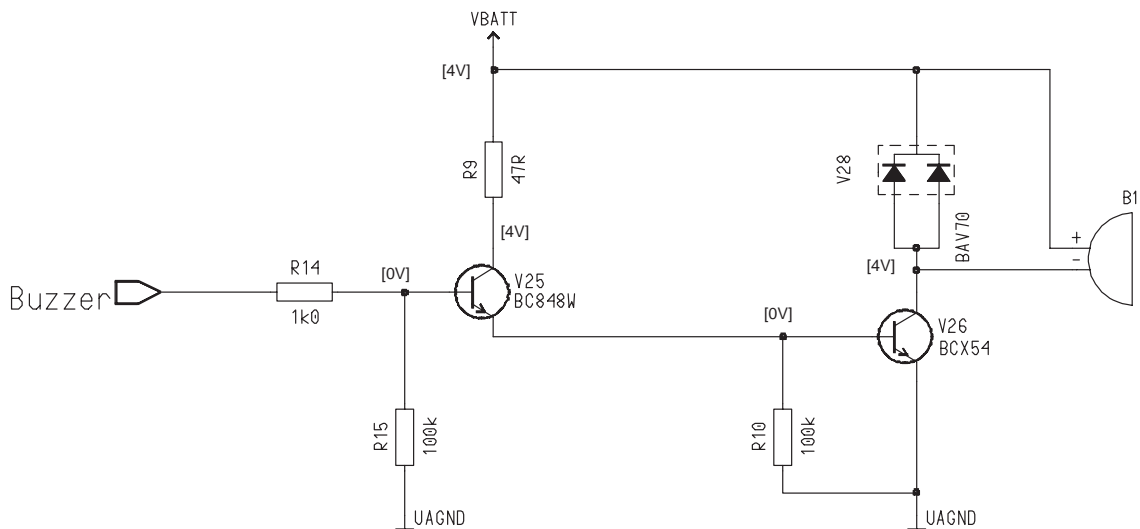

Typical value for node is marked with black when circuit is not active
Typical value for node is marked with gray when circuit is active

Speaker

The speaker is sealed to the A-cover and the UI PCB with a silicon gasket for more constant frequency response. The speaker needs 6pcs of 1.2mm holes under component for leaking sound pressure into the RF-section through the UI module and 7pcs of 0.9mm holes in the left-hand corner of the UIM to leak from RF-section back to up cavity of phone. The RF-section between the UI module and the engine acts like a sound cage. This gives better sound quality.

The silicon gasket and the speaker itself act as water proofing elements in that area. Water may come into the speaker space between the speaker and the A-cover but not further into the phone from there. On the A-cover there are 3 pcs leaking holes which are not located top of the speaker. These holes make a better sound quality and less sensitivity for how tightly the user presses the phone against his/her ear.

Parts list of UE4S (EDMS Issue 4.3)

Code: 0201360

ITEM	CODE	DESCRIPTION	VALUE	TYPE
R001	1430043	Chip resistor	2.2 k	5 % 0.063 W 0603
R002	1430155	Chip resistor	15	5 % 0.063 W 0603
R004	1430047	Chip resistor	3.3 k	5 % 0.063 W 0603
R006	1430043	Chip resistor	2.2 k	5 % 0.063 W 0603
R007	1430043	Chip resistor	2.2 k	5 % 0.063 W 0603
R008	1430155	Chip resistor	15	5 % 0.063 W 0603
R009	1430167	Chip resistor	47	5 % 0.063 W 0603
R010	1430087	Chip resistor	100 k	5 % 0.063 W 0603
R011	1825015	Varistor network 4xvwm18v ii	1206	1206
R014	1430035	Chip resistor	1.0 k	5 % 0.063 W 0603
R015	1430087	Chip resistor	100 k	5 % 0.063 W 0603
R016	1430159	Chip resistor	22	5 % 0.063 W 0603
R017	1430159	Chip resistor	22	5 % 0.063 W 0603
R019	1430122	Chip resistor	4.7 M	5 % 0.063 W 0603
C001	2320043	Ceramic cap.	22 p	5 % 50 V 0603
C002	2320043	Ceramic cap.	22 p	5 % 50 V 0603
C003	2320043	Ceramic cap.	22 p	5 % 50 V 0603
C004	2310784	Ceramic cap.	100 n	10 % 25 V 0805
C009	2310784	Ceramic cap.	100 n	10 % 25 V 0805
B001	5140087	Buzzer 85db 2600hz 3.6v 10x10x3.		10x10x3.5
Z001	3640035	Filt z>450r/100m 0r7max 0.2a		0603
Z002	3640035	Filt z>450r/100m 0r7max 0.2a		0603
H001	0201366	Gd40 us santra display module		
V001	4864388	Led	Green	0603
V002	4864388	Led	Green	0603
V003	4864388	Led	Green	0603
V004	4860005	Led	Green	0603
V005	4860005	Led	Green	0603
V009	4864388	Led	Green	0603
V010	4864388	Led	Green	0603
V012	4864388	Led	Green	0603
V013	4200836	Transistor	BCX19	npn 50V 0.5A SOT23
V017	4860005	Led	Green	0603
V020	4860005	Led	Green	0603
V021	4860005	Led	Green	0603
V022	4860005	Led	Green	0603
V023	4200836	Transistor	BCX19	npn 50V 0.5A SOT23
V025	4210100	Transistor	BC848W	npn 30 V SOT323
V026	4200875	Transistor	BCX54-16	npn 45V 1.5A SOT89
V027	4100278	Diode x 2	BAV70	70V 200mA COM CAT.SOT23
V028	4100278	Diode x 2	BAV70	70 V 200 mA COM CAT.SOT23
S001	5200120	Push button switch 6.4x5.2 smd		

9854259 PCB UE4S 41.0X121.0X0.8 M4 4/PA
PCB is not available separately!

Parts list of UE4S (EDMS Issue 6.3)

Code: 0201360

ITEM	CODE	DESCRIPTION	VALUE	TYPE
R001	1430043	Chip resistor	2.2 k	5 % 0.063 W 0603
R002	1430155	Chip resistor	15	5 % 0.1 W 0603
R004	1430047	Chip resistor	3.3 k	5 % 0.063 W 0603
R006	1430043	Chip resistor	2.2 k	5 % 0.063 W 0603
R007	1430043	Chip resistor	2.2 k	5 % 0.063 W 0603
R008	1430155	Chip resistor	15	5 % 0.1 W 0603
R009	1430167	Chip resistor	47	5 % 0.063 W 0603
R010	1430087	Chip resistor	100 k	5 % 0.063 W 0603
R011	1825015	Varistor network 4xvwm18v ii	1206	1206
R014	1430035	Chip resistor	1.0 k	5 % 0.063 W 0603
R015	1430087	Chip resistor	100 k	5 % 0.063 W 0603
R016	1430159	Chip resistor	22	5 % 0.063 W 0603
R017	1430159	Chip resistor	22	5 % 0.063 W 0603
R019	1430122	Chip resistor	4.7 M	5 % 0.063 W 0603
C001	2320043	Ceramic cap.	22 p	5 % 50 V 0603
C002	2320043	Ceramic cap.	22 p	5 % 50 V 0603
C003	2320043	Ceramic cap.	22 p	5 % 50 V 0603
C004	2310784	Ceramic cap.	100 n	10 % 25 V 0805
C009	2310784	Ceramic cap.	100 n	10 % 25 V 0805
B001	5140087	Buzzer	85db 2.6khz.	11x10x3.5
Z001	3640035	Filt z>450r/100m 0r7max 0.2a		0603
Z002	3640035	Filt z>450r/100m 0r7max 0.2a		0603
H001	0201366	Gd40 US Santra display module		
V001	4864388	Led	Green	0603
V002	4864388	Led	Green	0603
V003	4864388	Led	Green	0603
V004	4860005	Led	Green	0603
V005	4860005	Led	Green	0603
V009	4864388	Led	Green	0603
V010	4864388	Led	Green	0603
V012	4864388	Led	Green	0603
V013	4200836	Transistor	BCX19	npn 50 V 0.5 A
SOT23				
V017	4860005	Led	Green	0603
V020	4860005	Led	Green	0603
V021	4860005	Led	Green	0603
V022	4860005	Led	Green	0603
V023	4200836	Transistor	BCX19	npn 50 V 0.5 A
SOT23				
V025	4210100	Transistor	BC848W	npn 30 V SOT323
V026	4200875	Transistor	BCX54-16	npn 45 V 1.5 A
SOT89				
V027	4100278	Diode x 2	BAV70	70 V 200 mA COM-
CAT.SOT23				

